

LINE ARRAY DRIVER

KEY FEATURES

- Wave guide fulfilling requirements for Line Array applications.
- Neodymium magnetic circuit for high efficiency.
- Effective acoustical coupling up to 16 kHz.
- True 108 dB sensitivity 1w @ 1m (averaged 1-7 kHz).
- 0.8 kHz minimum recommended crossover frequency.
- 3" voice coil for superior power handling (80W).



GENERAL DESCRIPTION

This combination of high power neodymium compression driver with wave guide gives a straightforward solution to build a Line Array System, solving the difficult problem of achieving an optimum coupling between adjacent high frequency transducers. Instead of using expensive and complicated wave-shaping devices, a simple but effective wave guide transforms the circular aperture of the compression driver into a rectangular surface, without excessive angle aperture to provide low curvature to the acoustic wavefront, arriving to fulfill the curvature requirement for optimal acoustic coupling between adjacent sources until 16 kHz. This is achieved with the minimum possible length for low distortion, but without being excessively short, which would cause strong high frequency interferences. The 3" diameter voice coil and diaphragm construction allows a low cross-over frequency. This makes this solution adequate for use with 5", 6.5", 8" and 10" speaker sizes, facilitating the high frequency requirements of the Line Array mid band speakers.

FREQUENCY RESPONSE AND DISTORTION CURVES

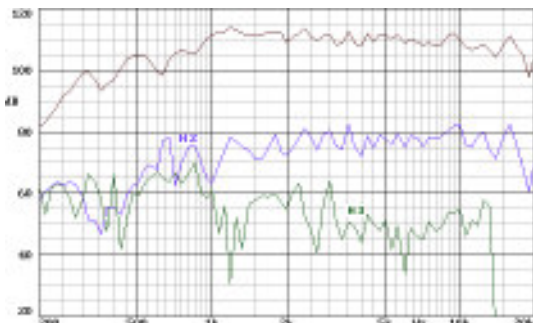

Note: on axis frequency response measured with two waveguides coupled to a 90° x 5° horn in anechoic chamber, 1w @ 1m.

FREE AIR IMPEDANCE CURVE

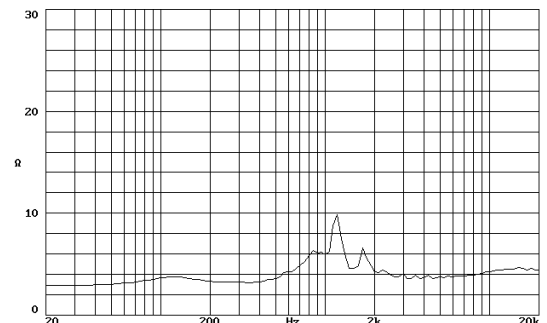

HORIZONTAL DISPERSION

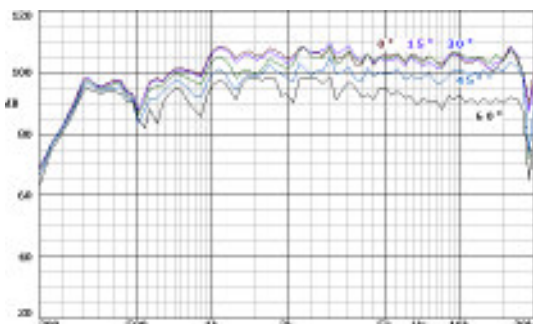

Notes: dispersion measured with two waveguides coupled to a 90° x 5° horn in anechoic chamber, 1w @ 2m. All angle measurements are from the axis (45° means ±45°)

VERTICAL DISPERSION

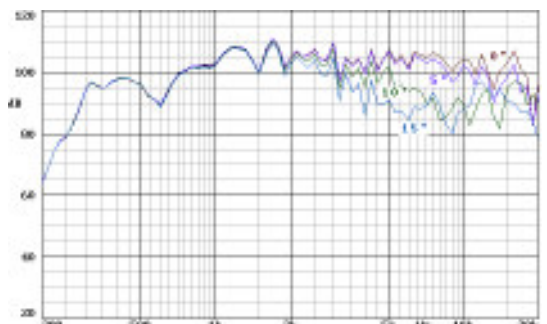

Notes: dispersion measured with two waveguides coupled to a 90° x 5° horn in anechoic chamber, 1w @ 2m. All angle measurements are from the axis (45° means ±45°)

TECHNICAL SPECIFICATIONS

Throat diameter	36 mm. 1.4 in.
Rated impedance	8 ohms.
Minimum impedance	7.2 ohms. @ 3 kHz
D.C. Resistance	5.5 ohms.
Power capacity *	80 w AES above 1 kHz
Program power	160 w above 1 kHz
Sensitivity **	108 dB 1 w @ 1m coupled to TD-385 horn
Frequency range	0.6 - 20 kHz
Recommended crossover	800 Hz or higher (12 dB/oct. min.)
Voice coil diameter	72.2 mm. 2.87 in.
Magnetic assembly weight	2.1 kg. 4.62 lb.
Flux density	2 T
BL factor	11 N/A

MOUNTING INFORMATION

Overall diameter	123 mm. 4.84 in.
Depth	268.5 mm. 10.57 in.
Mounting	Four M6 threaded holes, 90° apart on 101.6 mm (4 in.) diameter circle. Mounting hardware is supplied.
Net weight (1 unit)	2.62 kg. 5.76 lb.
Shipping weight (2 units)	5.65 kg. 12.43 lb.

MATERIALS

- **Waveguide:** synthetic resin.
- **Driver diaphragm:** titanium.
- **Driver voice coil:** edgewound aluminium ribbon wire.
- **Driver voice coil former:** kapton.
- **Driver magnet:** neodymium.

DIMENSION DRAWINGS

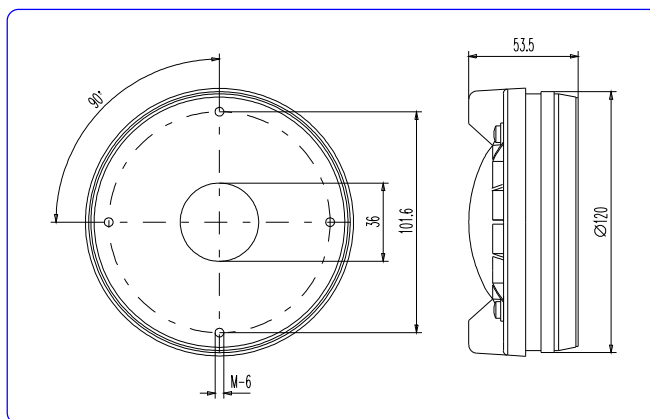
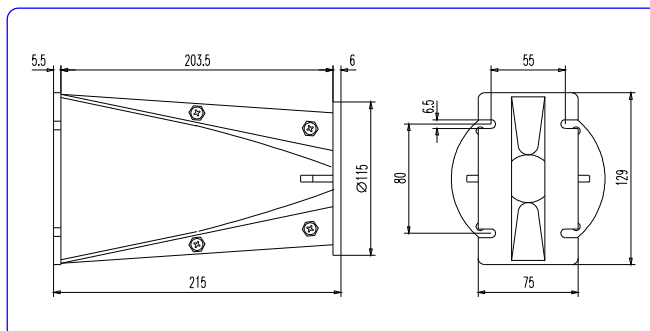

Notes:

*The power capacity is determined according to AES2-1984 (r2003) standard.
Program power is defined as the transducer's ability to handle normal music program material.
**Sensitivity was measured at 1 m distance, on axis, with 1 w input, averaged in the range 1-7 kHz.

DRIVER BEHAVIOUR WITH HORN

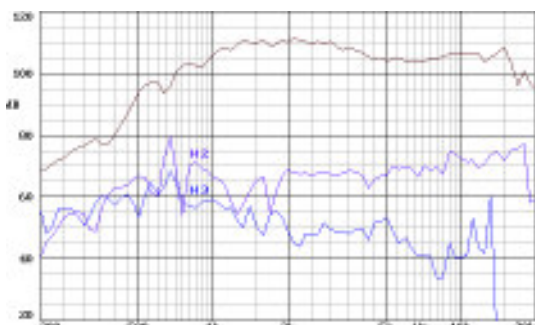

Note: on axis frequency response measured coupled to TD-385 in anechoic chamber, 1w @ 1m.

DRIVER BEHAVIOUR WITH HORN

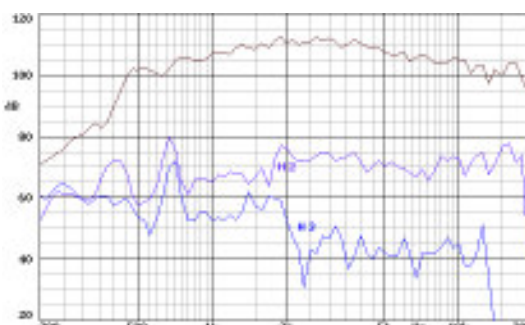

Note: on axis frequency response measured coupled to TD-565 in anechoic chamber, 1w @ 1m.



acústica beyma, s.a.

Polígono Industrial Moncada II · C/. Pont Sec, 1c · 46113 MONCADA - Valencia (Spain)
· Tel. (34) 96 130 13 75 · Fax (34) 96 130 15 07 · <http://www.beyma.com> · E-mail: beyma@beyma.com